

Instructions for measuring the diameter of XC poles in order to define the suitable ferrule for mounting

1. Remove the old ferrule
2. Measure the diameter of the pole at the position **a**
3. Measure the diameter of the pole at the position **b** which is 45 mm from bottom of the pole
4. Write a note with both measures **a and b (in mm)** in the comment when placing an order

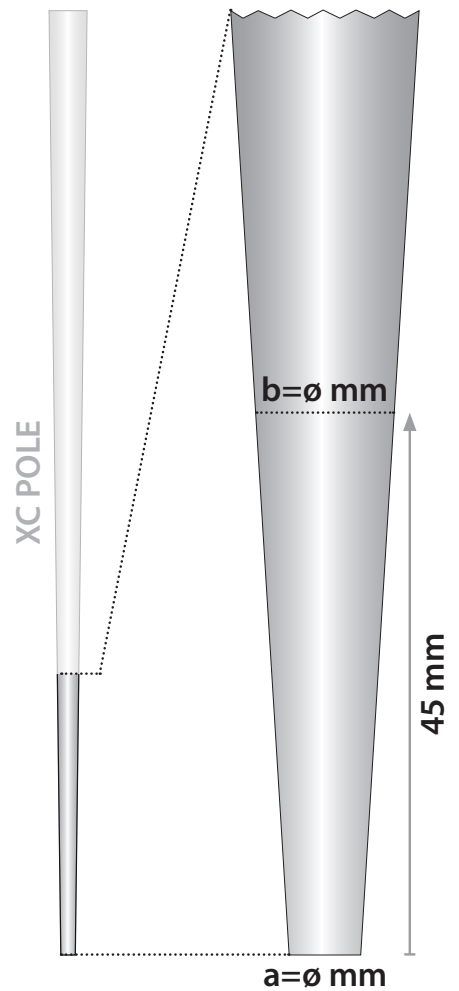

2. Measure the diameter of the pole at the position **a**

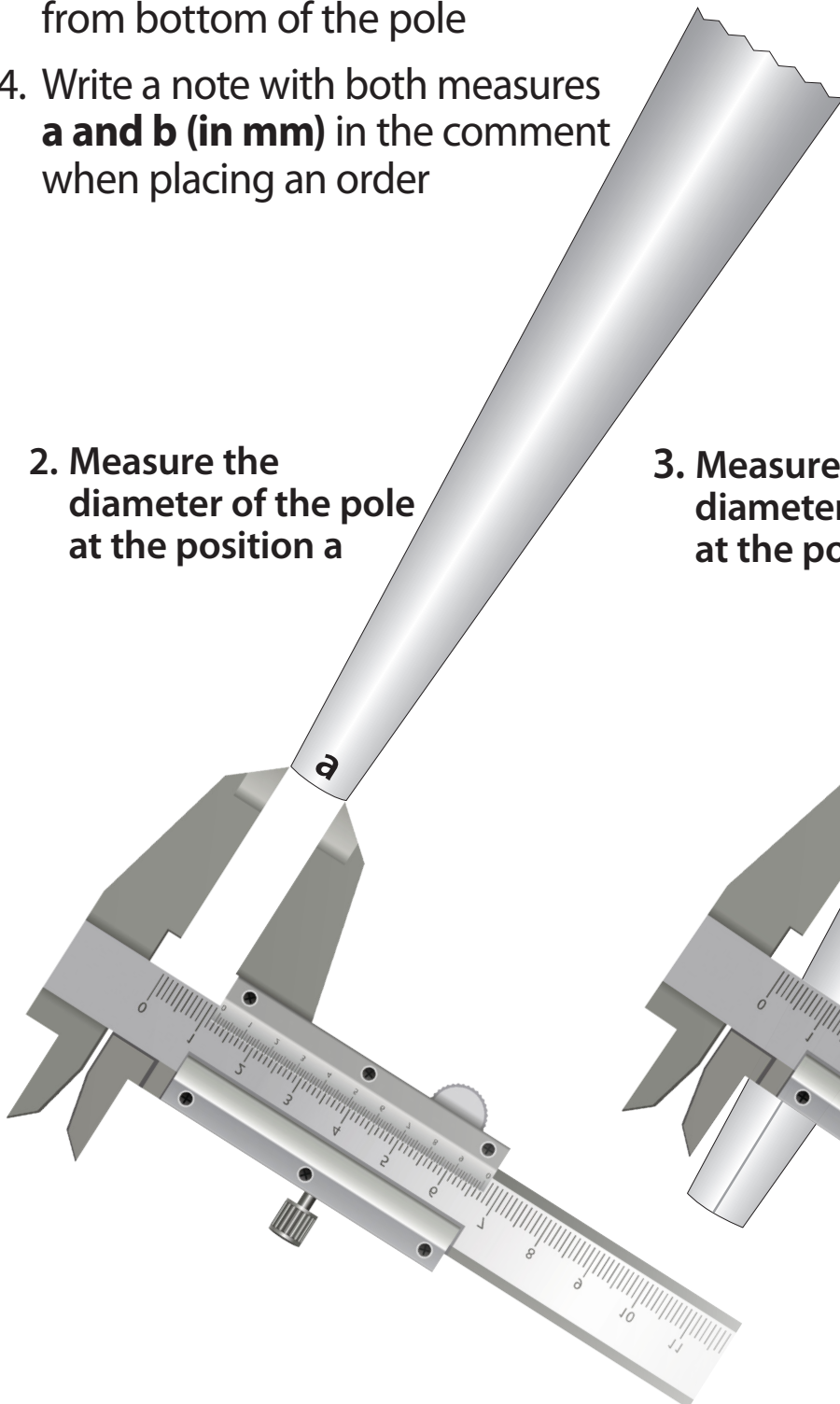

3. Measure the diameter of the pole at the position **b**

